

# A Software Tool for Verification of Network Configuration

Ramalingam Swaminathan , Baljinder Sandhu , Nita Goel , Pulak Dhar  
Cistel Technology, 210 Colonnade Road, Suite 204, Nepean ON K2E 7L5  
( rswami , baljinder, nbansal, pulak )@cistel.com

## 1. Introduction

We present a software tool for network configuration verification. IT managers are getting more and more concerned about impact of applications on the operation and performance of a network on which those applications are running. IT departments are in the challenging position of having to manage technology for operational excellence in parallel with managing business excellence. Thus the applications running on a network ought to be available when needed, run fast and perform reliably for all users. There is a need for a facility that would help in identifying configuration changes (hardware, software and firmware) in the networked computing infrastructure. The final aim of the research is to develop a comprehensive Configuration Verification Tool that will enable the measurement of the running applications and management of their Quality of Service (QoS).

## 2.High Level View of the Project

Due to complexity, this research project is broken down into four major phases using two freeware products called “Back Orifice 2000” and “My SQL”

In Phase I (Test Configuration) the research team will focus on building a baseline of the network configuration with typical computational figures.

In Phase II (Test Environment) the research team will reuse the modeling approach of Phase I and work on designing and building a freeware Database repository to represent

key attributes of the whole network. Freeware is necessary to reduce the solution overheads.

In Phase III (Test Assessment) the research team will work on designing and building the model that assesses the changes (Fig 1) to any attribute in the network. The idea is to provide a simulation of a real network in the test lab environment.

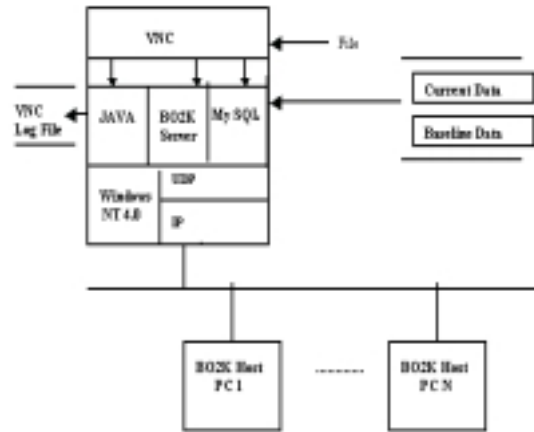

Fig 1 – Legend:  
VNC : Software Application for Verification of Network Configuration.  
PC 1 to N : Nodes in the Network.

In Phase IV (Integration & System Test), the research team will work on testing that the deployment package installs successfully and also determine the “Shrink Wrap” configuration to satisfy installation requirements.

## 3. Description of the Work done

### 3.1. Baseline Model

The work involved in achieving the objectives of Phase I of this project has been accomplished. The network has been modeled as a set of resources (e.g., PCs, printers, routers). Each resource has a set of attributes that are checked to see if

they are within acceptable bounds. This has been done using a program to compare the "current" version of a network used for testing, against a desired "baseline" version of that network. It compares 5 key parameters of PC nodes in a network, CPU, BIOS, Hard Disk Size and IP address and Operating System

### **3.2. Configuration of the Verification Testing Model**

In the Test Configuration Phase we investigated tools and methods to find a minimum set of parameters to validate a test configuration and then look for freeware based solutions to collect and analyze these parameters

### **3.3 Validation of the developed application.**

We created a Microsoft Visual Basic application to verify the network configuration of 5 PCs running the Microsoft Windows Operating System. The application uses the freeware software "Back Orifice 2000" to collect data from remote PCs and MySQL to store and retrieve the data.

### **4. Conclusions & Further Work**

- ✓ Data such as "BIOS Manufacturer" and "version number", "operating system" and "Hard disk size" are useable to determine if the PC is in a usable state.
- ✓ Inequalities are needed to determine if some attributes are acceptable, e.g., free hard disk space > 500 MB.
- ✓ A flexible data structure to store "Baseline" data is needed, as the application has to accommodate

variations in attributes between different user network configuration and changes in data structures from the software we use.

- ✓ A simple, but more informative than a mere progress bar, GUI consisting of green (Test Pass) and red (Test Fail) circles to show the progress of the testing a node.

A program, which extends the functionality of the existing application by including some software attributes of a Windows based PC including PC Software, e.g., "Microsoft Office 4.0.2", and some Cisco router attributes in a network including Cisco router version number, will be used towards accomplishing the next phases of this project.

### **5. References:**

- [1] P. Oppenheimer: "Top -down Network Design"
- [2] M. W. Murhammer et al: "TCP /IP Tutorial and Technical Overview"
- [3] Thom Hogan: The Programmer's PC Sourcebook
- [4] Scott Muller: "Upgrading and Repairing PCs"
- [5] Williams: "Windows2000 System Programming"
- [6] Schmidt: "The Complete Reference Java2"
- [7] Dan Appleman: "Guide to Win32 API"
- [8] Stevens: "C++ "
- [9] Randy Jay Yarger, George Reese & Tim King: "MySQL & mSQL"
- [10] NuSphere MySQL Maunals
- [11] Deitel & Dietel: "Visual Basic 6 How to Program"
- [12] William R Vaughn: "Hitchhiker's Guide to Visual Basic and SQL Server Sixth Edition"